

## AGENDA

### FLOWER MOUND TOWN COUNCIL REGULAR MEETING

5/17/2022

FLOWER MOUND TOWN HALL, 2121 CROSS TIMBERS ROAD  
FLOWER MOUND, TEXAS

6:00 P.M.

A public reception will be held at 5:30 p.m. in the Town Hall lobby for outgoing and newly elected council members.

---

An agenda information packet is available online at [flower-mound.com/AgendaCenter](http://flower-mound.com/AgendaCenter)

---

Comments regarding any agenda item can be sent to the Town Council by emailing [towncouncil@flower-mound.com](mailto:towncouncil@flower-mound.com) or by calling 972.874.6005 and leaving a message.

**A. CALL MEETING TO ORDER**

**B. INVOCATION**

Bobbie J. Mitchell, Denton County Commissioner, Precinct 3

**C. PLEDGE OF ALLEGIANCE TO THE AMERICAN FLAG AND TO THE TEXAS FLAG**

*"Honor the Texas flag; I pledge allegiance to thee, Texas, one state under God, one and indivisible."*

**D. PRESENTATIONS**

1. Proclamation of National Public Works Week, May 15-21

**E. PUBLIC COMMENT**

The purpose of this item is to allow the public an opportunity to address the Town Council regarding any item on this agenda. Issues regarding daily operational or administrative matters should first be dealt with by calling Town Hall at 972.874.6000 during business hours.

In accordance with the Texas Open Meetings Act, the Town Council is restricted from discussing or acting on items not listed on the agenda.

To speak to Council during public comment, please fill out a [comment form](#).

- Speakers are limited to 3 minutes, a tone will sound at 30 seconds left and when time has expired, and times may be adjusted by the mayor
- Speakers must address their comments to the Town Council
- Please state your name and address when speaking

**F. CONSENT ITEMS**

This part of the agenda consists of non-controversial or "housekeeping" items required by law. Items may be removed from Consent by any council member by making such request prior to a motion and vote.

1. Minutes 5/2- Consider approval of the minutes from a regular meeting of the Town Council held on May 2, 2022.

## Town Council Meeting Agenda

May 17, 2022

Page 2

2. 2023 Ford F-450 Diesel Ambulance- Consider approval of the purchase of a 2023 Ford F-450 Frazer Type 1 Ambulance for the Fire and Emergency Services department from Frazer, LTD. through the Houston-Galveston Area Council of Governments (H-GAC) cooperative purchasing program in the total amount of \$273,338.00; and authorization for the Mayor to execute same on behalf of the Town.
3. Canvass Election- Consider approval of an ordinance canvassing returns and declaring results of a general election held May 7, 2022, for the purpose of electing Council Member Places 1 and 3 and providing an effective date.

### **G. RECOGNITION OF AND REMARKS FROM OUTGOING COUNCILMEMBER BEN BUMGARNER**

### **H. OATH OF OFFICE FOR NEWLY ELECTED OFFICIALS**

1. Administer Oath of Office to newly elected Councilmember Place 1, Adam Schiestel and issue Certificate of Election.
2. Administer Oath of Office to newly elected Councilmember Place 3, Brian Taylor and issue Certificate of Election.

### **I. REMARKS FROM NEWLY ELECTED COUNCILMEMBERS**

### **J. CLOSED MEETING**

The Town Council to convene into closed meeting pursuant to Texas Government Code Chapter 551, including, but not limited to, Sections 551.071, and 551.074, for consultation with Town Attorney, personnel, as follows:

- a. Consultation with Town Attorney.
  1. Case 4:22-cv-00371 La Estancia Investments, L.P. v. Town of Flower Mound, Texas et al
  2. Housing Discrimination Complaint
- b. Discuss and consider election of Mayor Pro Tem and Deputy Mayor Pro Tem

The Town Council may convene in executive session to conduct a private consultation with its attorney on any legally posted agenda item, when the Town Council seeks the advice of its attorney about pending or contemplated litigation, a settlement offer, or on a matter in which the duty of the attorney to the governmental body under the Texas Disciplinary Rules of Professional Conduct of the State Bar of Texas clearly conflicts with the provisions of Chapter 551, including the above referenced items.

### **K. RECONVENE TO REGULAR MEETING**

The Town Council to reconvene into an open meeting to take any action deemed necessary as a result of the closed meeting.

### **L. COORDINATION OF CALENDARS**

1. A special work session is scheduled for 2:00 pm, Wednesday, May 25.
2. A regular meeting is scheduled for Monday, June 6.

### **M. ADJOURN MEETING**

**Town Council Meeting Agenda**  
**May 17, 2022**  
**Page 3**

I do hereby certify that the Notice of Meeting was posted on the bulletin board at the Town Hall for the Town of Flower Mound, Texas, in a place convenient and readily accessible to the general public at all times and said Notice was also posted on the Town's website in accordance with GC Section 551.056 on the following date and time: May 13, 2022, at 1:20 p.m., at least 72 hours prior to the scheduled time of said meeting.

---

**Theresa Scott, Town Secretary**

The Flower Mound Town Hall and Jody Smith Hall are wheelchair accessible. Requests for accommodations or interpretive services must be made 48 hours prior to this meeting by contacting Theresa Scott, Town Secretary, at 972.874.6076. Additional time limits will be provided to members of the public that need to address the Town Council through a translator.



## TOWN COUNCIL AGENDA ITEM NO. 1

### CONSENT ITEM

---

**DATE:** May 17, 2022

**FROM:** Theresa Scott, Town Secretary

**ITEM:** Consider approval of the minutes from a regular meeting of the Town Council held on May 2, 2022.

---

**BACKGROUND INFORMATION:** The Town Council held a regular meeting on May 2, 2022.

**BOARD REVIEW/CITIZEN FEEDBACK:** N/A

**ALTERNATIVES/OPTIONS:** N/A

**FISCAL IMPACT:** N/A

**LEGAL REVIEW:** N/A

**ATTACHMENTS:**

1. Draft minutes 4/18

**DRAFT MOTION:** Move to approve as presented in the agenda caption.

**FLOWER MOUND TOWN COUNCIL MEETING OF MAY 2, 2022****PAGE 1**

**THE FLOWER MOUND TOWN COUNCIL REGULAR MEETING HELD ON THE 2ND DAY OF MAY 2022, IN THE FLOWER MOUND TOWN HALL, LOCATED AT 2121 CROSS TIMBERS ROAD IN THE TOWN OF FLOWER MOUND, COUNTY OF DENTON, TEXAS AT 6:00 P.M.**

[Click here](#) for meeting video link (subject to change)

The Town Council met in a regular meeting with the following members present:

Derek France	Mayor
Ben Bumgarner	Mayor Pro Tem
Sandeep Sharma	Deputy Mayor Pro Tem
Adam Schiestel	Councilmember Place 1
Jim Engel	Councilmember Place 4
Ann Martin	Councilmember Place 5

constituting a quorum with the following members of the Town Staff participating:

Theresa Scott	Town Secretary
Bryn Meredith	Town Attorney
James W. Childers	Town Manager
Tommy Dalton	Assistant Town Manager
Tiffany Bruce	Assistant Town Manager/Town Engineer
Lexin Murphy	Director of Planning Services
Melissa Demmitt	Director of Communications
Brian Waltenburg	Assistant Director of Engineering

**A. CALL MEETING TO ORDER**

Mayor France called the regular meeting to order at 6:00 p.m.

**B./C. INVOCATION/PLEDGE OF ALLEGIANCE TO THE AMERICAN FLAG AND THE TEXAS FLAG**

Chaplain Russ McNamer gave the invocation and Boy Scout Troop 451 led the pledges.

**D. PRESENTATIONS**

1. Proclamation and presentation of Hometown Hero-Jordyn Carlson

Mayor France recited the proclamation and presented it to his family.

2. Mental Health Proclamation

Mayor France recited the proclamation and presented it to Michelle Foster on behalf of WATCH, The Denton County Behavioral Health Leadership Team and Denton County MHMR.

3. Apraxia Proclamation

Mayor France recited the proclamation and presented it to Cooper Martin.

**FLOWER MOUND TOWN COUNCIL MEETING OF MAY 2, 2022****PAGE 2**

## 4. Parks Board and Community Development Corporation (CDC) update

Teresa Thomason, Chair, Parks Board and Mehul Desai, President, CDC

Ms. Thomason or Mr. Desai gave a presentation identifying or noting:

- Qualifications
- Parks Board duties
- Park and trail projects
- Looking ahead
- CDC background
- Sales tax funds use
- Project selection
- Rheudasil Park improvements
- Playground surfacing upgrades
- Heritage Park improvements
- Sport lighting improvements at Leonard & Helen Johns Park and Glenwick

**E. PUBLIC COMMENT**

*Names listed below don't necessarily reflect the order in which each person spoke and all addresses are located in Flower Mound unless otherwise indicated.*

	<b>Speaker names and address</b>	<b>Subject (as written on the form)</b>
1.	Greg Wilson, 637 Loma Alto Dr	Public comment
2.	Mary Kay Walker, 3229 Oak Meadow	SIMA
3.	Paul Stone, 1868 Meyerwood Ln	Ethics
4.	Bryan Webb, 4112 High Rd	Open Meetings Act
5.	Stacey, Karlie, Kenzie, Kammie, Leonard, 11500 Antler Ridge Way, Argyle	Thank you

**F. ANNOUNCEMENTS**

Councilmember Martin announced that May is Mental Health Awareness and encouraged everyone to seek resources for themselves or others in need.

Council Schiestel announced upcoming election information.

Councilmember Engel reported on the Fire and Police banquets honoring first responders. He also reporting having participated and graduated from the Citizens Fire Academy.

Deputy Mayor Pro Tem Sharma announced the May 7<sup>th</sup> Arts Festival event.

Mayor France reported that mosquito dunks are available at Town Hall for Flower Mound residents.

**G. TOWN MANAGER'S REPORT**

Mr. Childers provided background information about the Town's website redesign and Capital Improvement Project map.

- 1./2. Website redesign; Capital improvement project map

Ms. Demmitt gave a preview of the new Town website, and Mr. Waltenburg outlined the features of the new CIP map.

#### **H. FUTURE AGENDA ITEMS**

1. There were no future agenda item request.

#### **I. COORDINATION OF CALENDARS**

1. The regular meeting has been rescheduled from Monday, May 16, to Tuesday, May 17, in order to canvass the election.

Mayor France announced the above referenced meeting and confirmed that all members of Council plan to attend.

#### **J. CONSENT ITEMS**

1. Consider approval of the minutes from a regular meeting of the Town Council held on April 18, 2022.
2. Consider approval of the minutes from a work session of the Town Council held on April 21, 2022.
3. Consider Approval of a Farm Lease Agreement between the Town of Flower Mound and the Wayne Haynes Estate for the lease of Town Property located at 10300 Dunham Road; and authorize the Mayor to execute same on behalf of the Town.
4. Consider approval of the consumption of alcoholic beverages at the Flower Mound Senior Center during the SIM Auxiliary's Elite Chef Competition fundraiser.
5. Consider approval of the Professional Services Agreement with RJN Group, Inc., for Flow Monitoring and Analysis associated with the Inflow and Infiltration project, in the amount of \$90,496.00; and authorization for the Mayor to execute same on the behalf of the Town.
6. Consider approval of the purchase of one 2023 Ford F750 Regular Cab 31k GVWR Dump Truck per Town of Flower Mound Specifications and Vendor Quote from Sam Pack's Five Star Ford for Public Works in the amount of \$85,762.06.
7. Consider approval of a Charter Service Agreement with Durham School Services, L.P., in the amount of \$35,500 to provide shuttle buses for various special events and the day camp program; and authorization for the Mayor to execute same on behalf of the Town.
8. Consider approval of a First Amendment to the Professional Services Agreement with CP&Y, Inc., for the design phase services associated with the FM 2499 at FM 3040 Intersection Improvements project, to increase the design fee by \$23,960.00; and authorization for the Mayor to execute same on behalf of the Town.

Deputy Mayor Pro Tem Sharma moved to approve by consent Items 1 – 8, as presented in the agenda caption. Councilmember Engel seconded the motion. Each item, as approved by consent, is restated above, and if applicable, the Ordinance or Resolution caption for each, for the record.

**VOTE ON MOTION:***Motion passed***AYES: SCHIESTEL, SHARMA, BUMGARNER, ENGEL, MARTIN****NAYS: NONE****K. REGULAR ITEMS**

9. Public Hearing to consider approval of a Chapter 380 with Sunset Boulevard Partners, LLC (SBP), at 3301 Sunset Boulevard, for the economic development of Flower Mound, and authorization for the Mayor to execute same on behalf of Town.

**Staff Presentation**

Mr. Watson gave a presentation identifying or noting:

- Site location
- Renderings
- Incentive proposal
- Cost-benefit analysis
- Payback periods

and he responded to questions or comments from Council regarding:

- Sunset clauses
- Incentive number
- Cash grant purpose

**Developer Presentation**

Jimmie Archie, Realty Capital  
Brook Thomas, Hilton

Mr. Archie or Ms. Thomas gave a presentation identifying or noting:

- Background information
- Lakeside Village
- Lakeside site plan
- Lakeside Village site plan
- Lakeside Village office and hotel
- Site renderings
- Hotel Miramar and 3301 Sunset (activators of Lakeside Village)
- Wedding chapel
- Walking trails, retail/restaurants along Sunset Blvd and events on the Village lawn
- Amphitheater and biking on Rockledge Park and Northshore Trail
- Project stakeholders
- Curio Collection by Hilton and Miramar, including photo examples

and he responded to questions or comments from Council regarding:

- Phasing
- Hotel classification
- Incentives as it relates to parking



**FLOWER MOUND TOWN COUNCIL MEETING OF MAY 2, 2022****PAGE 5**

Mayor France opened the Public Hearing at 7:22 p.m. No one spoke. Mayor France closed the Public Hearing at 7:22 p.m.

Mayor Pro Tem Bumgarner moved to approve as presented. Councilmember Engel seconded the motion.

**Council Discussion**

There was Council discussion regarding:

- Use of incentives
- Confidence of hotel use coming forward

**VOTE ON MOTION:***Motion passed***AYES: MARTIN, ENGEL, BUMGARNER, SHARMA, SCHIESTEL****NAYS: NONE**

10. Consider a request for a Development Plan (DP21-0008 – Oakbridge Crossing) to develop a residential subdivision. The property is generally located east of Long Prairie Road and north of Spinks Road. (PZ recommended approval by a vote of 6 to 0 at its April 25, 2022, meeting.)

**Staff Presentation**

Ms. Murphy gave a presentation identifying or noting:

- General and detailed location
- Land use and zoning
- Development plan
- Site photos
- Landscape plan and details

and she responded to questions from Council regarding:

- Master Plan alignment

Mayor Pro Tem Bumgarner moved to approve as presented. Councilmember Schiestel seconded the motion.

**VOTE ON MOTION:***Motion passed***AYES: SCHIESTEL, SHARMA, BUMGARNER, ENGEL, MARTIN****NAYS: NONE**

11. Public Hearing to consider an ordinance for rezoning (ZPD21-0013 – Orchard Flower) to amend Planned Development No. 120 (PD-120) with Single-Family District-5 (SF-5) and Retail District-2 (R-2) uses, to modify the conceptual plans and elevations for the non-residential portion and modify the development standards, with an amendment to the previously approved exception to Sec 82-303 for the compatibility setback, and with certain modifications and exceptions to the Code of Ordinances. The property is generally located at the northwest corner of Flower Mound Road and Old Orchard Lane. (PZ tabled this item to a date uncertain by a vote of 6 to 0 at its December 13, 2021, meeting.) (PZ recommended approval by a vote of 6 to 0 at its April 25, 2022, meeting.)

### Staff Presentation

Ms. Murphy gave a presentation identifying or noting:

- General and detailed location
- Land use and zoning
- Site photos
- Approved concept site plan
- Approved amended concept site plan
- Concept plan
- PD Modifications
- Concept elevations – area

and she responded to questions or comments from Council regarding:

- Setbacks
- Masonry wall changes and neighborhood feedback
- Easement access

Mayor France opened the Public Hearing at 7:38 p.m. No one spoke. Mayor France closed the Public Hearing at 7:39 p.m.

### Council Discussion

There was Council discussion about the changes made since the P & Z meeting.

Councilmember Engel moved to approve as presented. Councilmember Schiestel seconded the motion.

### ORDINANCE NO. 25-22

**AN ORDINANCE OF THE TOWN OF FLOWER MOUND, TEXAS, AMENDING ORDINANCE NOS. 12-12, 52-14, AND 27-18 WHICH ESTABLISHED AND LATER AMENDED PLANNED DEVELOPMENT DISTRICT NO. 120 (PD-120) ON CERTAIN PROPERTY DESCRIBED AS 2.734 ACRES OF LAND AND BEING ALL OF LOTS 1 AND 2, BLOCK A OF THE GODDARD SCHOOL AT FLOWER MOUND; BY AMENDING THE DEVELOPMENT STANDARDS; BY MODIFYING THE DEVELOPMENT STANDARDS, THE CONCEPTUAL PLANS, AND THE CONCEPTUAL ELEVATIONS FOR THE RETAIL DISTRICT-2 (R-2) PORTION, IN ACCORDANCE WITH SPECIFIC REQUIREMENTS STATED HEREIN AND EXHIBITS ATTACHED HERETO; PROVIDING THIS ORDINANCE SHALL BE CUMULATIVE OF ALL ORDINANCES; PROVIDING A SEVERABILITY CLAUSE; PROVIDING A PENALTY CLAUSE; PROVIDING A SAVINGS CLAUSE; PROVIDING FOR PUBLICATION IN THE OFFICIAL NEWSPAPER; AND PROVIDING AN EFFECTIVE DATE.**

### VOTE ON MOTION:

**AYES: MARTIN, ENGEL, BUMGARNER, SHARMA, SCHIESTEL  
NAYS: NONE**

*Motion passed*

**L. BOARDS/COMMISSIONS**

Discuss and consider resignations, appointments, evaluations, reassignments, discipline, or dismissals for the following boards or commissions: Animal Services Board, Cultural Arts Commission, Environmental Conservation Commission, Parks Board, School Liaison Committee, SMARTGrowth Commission, Tax Increment Reinvestment Zone Number One (TIRZ #1), Transportation Commission, and Veterans Liaison Board.

No discussion.

**M./N. CLOSED/OPEN MEETING**

The Town Council convened into a closed meeting at 7:40 p.m. on May 2, 2022, pursuant to Texas Government Code Chapter 551, including, but not limited to, Sections 551.071, 551.072, 551.074, and 551.087 for consultation with attorney, and to discuss matters relating to real property, personnel, and economic development negotiations, and reconvened into an open meeting at 8:51 p.m. on May 2, 2022, to take action on the items as follows:

- a. Consultation with Attorney.
  1. 2006 Rule 11 agreement and dismissal, Cause No. 2005-20153-158 and Flower Mound Ranch Development Applications
  2. Agricultural Zoning  
No action taken.
- b. Discuss and consider purchase, exchange, lease or value of real property for parks, public rights-of-way, and/or other municipal purposes and all matters incident and related thereto. No action taken.  
No action taken.
- c. Discuss and consider resignations, appointments, or evaluations for the following boards or commissions: Board of Adjustment/Oil & Gas Board of Appeals, Community Development Corporation, and Planning and Zoning Commission. No action taken.  
No action taken.
- d. Discuss and consider economic development incentives, including retail centers, corporate relocation/expansion/retention, senior housing, hospitality projects, and performance related to certain incentive agreements. No action taken.  
No action taken.
- e. Deliberate the appointment, employment, evaluation, reassignment, duties, discipline, or dismissal of the Town Manager.

Councilmember Martin moved to authorize the Mayor of Flower Mound to execute an amendment to the Town Manager's employment agreement to extend his residency requirement date to June 3, 2022. Mayor Pro Tem Bumgarner seconded the motion.

**VOTE ON MOTION:***Motion passed***AYES: SCHIESTEL, SHARMA, BUMGARNER, ENGEL, MARTIN****NAYS: NONE**

- f. Discuss and consider appointment of an additional Alternate Municipal Court Judge, including job duties and responsibilities, and all matters incident and related thereto.

Deputy Mayor Pro Tem Sharma moved to approve an ordinance appointing Alissa Janke as Associate Municipal Court Judge, and with the same terms and conditions of the current Alternate Municipal Court Judge, subject to her offer acceptance. Mayor Pro Tem Bumgarner seconded the motion.

**ORDINANCE NO. 26-22**

**AN ORDINANCE OF THE TOWN COUNCIL OF THE TOWN OF FLOWER MOUND, TEXAS APPOINTING AN ASSOCIATE JUDGE OF THE MUNICIPAL COURT OF RECORD IN THE TOWN OF FLOWER MOUND; PROVIDING THIS ORDINANCE SHALL BE CUMULATIVE OF ALL ORDINANCES; PROVIDING A SEVERABILITY CLAUSE; AND PROVIDING AN EFFECTIVE DATE.**

**VOTE ON MOTION:***Motion passed***AYES: MARTIN, ENGEL, BUMGARNER, SHARMA, SCHIESTEL****NAYS: NONE****O. ADJOURN REGULAR MEETING**

Mayor France adjourned the meeting at 8:53 p.m. on Monday, May 2, 2022, and all were in favor.

**TOWN OF FLOWER MOUND, TEXAS**

---

**DEREK FRANCE, MAYOR**
**ATTEST:**

---

**THERESA SCOTT, TOWN SECRETARY**



## TOWN COUNCIL AGENDA ITEM NO. 2

### CONSENT ITEM

**DATE:** May 17, 2022

**FROM:** Paul Henley, Fire Chief *PH*

**ITEM:** Consider approval of the purchase of a 2023 Ford F-450 Frazer Type 1 Ambulance for the Fire and Emergency Services department from Frazer, LTD. through the Houston-Galveston Area Council of Governments (H-GAC) cooperative purchasing program in the total amount of \$273,338.00; and authorization for the Mayor to execute same on behalf of the Town.

**BACKGROUND INFORMATION:** The Fire and Emergency Services Department is requesting the purchase of (1) 2023 Ford F-450 Frazer Type 1 Ambulance per Town of Flower Mound Specifications from Frazer, LTD. This equipment will be purchased through the H-GAC cooperative purchasing program. The vehicle is part of a budget amendment approved by Town Council on April 18, 2022, for the Vehicle Equipment Replacement Fund (VERF) budget replacing a 2015 Ford F450 (Unit # 61000-02) Siddons Martin Ambulance. Delivery of the ambulance is expected within 13 months after receipt of order. Frazer is offering a trade-in allowance. Additional equipment totaling approximately \$60,000.00 will be ordered at a later date and installed by Frazer, LTD.

Pricing Breakdown:

Subtotal	\$312,338.00
H-GAC processing	\$ 1,000.00
Trade-in of Unit 61000-02	<u>\$( 40,000.00)</u>
Purchase Price	\$273,338.00

**FISCAL IMPACT:** \$273,338.00

Proposed Expenditure/(Revenue):	Account Number(s):
\$273,338.00	100-565-84500-6130

**Finance Review by:** Tammy Wilson, Chief Financial Officer *tw*

**LEGAL REVIEW:** N/A

**ATTACHMENTS:**

1. H-GAC Pricing Worksheet
2. Specifications
3. Fleet Bid Award Recommendation

**DRAFT MOTION:** Move to approve as presented in the agenda caption.

<b>HGACBuy</b>		<b>CONTRACT PRICING WORKSHEET For MOTOR VEHICLES Only</b>		<b>Contract No.:</b>	AM10-20	<b>Date Prepared:</b>	3/29/2022
<b>This Worksheet is prepared by Contractor and given to End User. If a PO is issued, both documents MUST be faxed to H-GAC @ 713-993-4548. Therefore please type or print legibly.</b>							
<b>Buying Agency:</b>	Flower Mound Fire Department			<b>Contractor:</b>	Sterling McCall Ford 2869 HGAC		
<b>Contact Person:</b>	Jonathan Castro			<b>Prepared By:</b>	Pablo Cantu		
<b>Phone:</b>				<b>Phone:</b>	(281) 588-5007		
<b>Fax:</b>				<b>Fax:</b>	(281) 588-5150		
<b>Email:</b>	jonathan.castro@flower-mound.com			<b>Email:</b>	pcantu@sterlingmccallford.com		
<b>Product Code:</b>	AM20HD13	<b>Description:</b>	Type I 14' on Ford F-450 Diesel 4x2 Reg Cab				
<b>A. Product Item Base Unit Price Per Contractor's H-GAC Contract:</b>							<b>\$194,000.00</b>
<b>B. Published Options - Itemize below - Attach additional sheet(s) if necessary - Include Option Code in description if applicable. (Note: Published Options are options which were submitted and priced in Contractor's bid.)</b>							
<b>Description</b>		<b>Cost</b>	<b>Description</b>		<b>Cost</b>		
1172	Module // Module // Door Forward	\$5,000.00	1163	Module // Ground Lights // Ground Light at Peri	\$3,500.00		
1066	Chassis // Heat Shielding // Heat Shielding	\$1,750.00	1180	Module // Opticom // GTT Opticom on Front Wa	\$2,000.00		
1076	Chassis // Paint // Paint Two Tone	\$6,000.00	1140	Module // Electric Locks // Entry doors & Comp	\$4,000.00		
1086	Chassis // Suspension // LiquidSpring on Rear Axle	\$12,000.00	1167	Module // Hold-Open // Gas Hold-Opens on Cor	\$1,000.00		
1078	Chassis // Running Boards // ArcRite Running Board w/	\$1,250.00	1102	Module // Action Wall // Electric O2 with Monit	\$2,000.00		
1065	Chassis // Grille Guard // Black Ranch Hand Grille Gua	\$1,500.00	1012	General // All products listed in the current Tech	\$1,700.00		
1031	Chassis // Air Horn System // Dual 10" & 12" Air Horns	\$1,250.00	1108	Module // Cabinets // Cabinet to the Rear of the	\$1,000.00		
1032	Chassis // Air Horn System // Fast RecoveryCompressor	\$1,500.00	1107	Module // Cabinet // Triple Squad Bench Cabine	\$1,000.00		
1193	Module // PowerSource // MEPS	\$15,000.00	1153	Module // Floor // Install Stryker PowerLoad sys	\$1,750.00		
1188	Module // Paint // Two Tone 14'	\$3,750.00	1013	General // All products listed in the current Whe	\$9,600.00		
1128	Module // Conspicuity // Conspicuity on the Rear of the	\$1,750.00	<b>Subtotal From Additional Sheet(s):</b>		\$11,900.00		
1144	Module // Exterior // Striping and lettering // Pricing //	\$3,500.00	<b>Subtotal B:</b>		\$93,700.00		
<b>C. Unpublished Options - Itemize below / attach additional sheet(s) if necessary. (Note: Unpublished options are items which were not submitted and priced in Contractor's bid.)</b>							
<b>Description</b>		<b>Cost</b>	<b>Description</b>		<b>Cost</b>		
Furnish and install SmithWorks IV warmer		\$1,000.00	Full height divider forward of O2 bottle		\$1,000.00		
Paint front grille, front Ford Emblem		\$600.00	Temporary supply chain surcharge		\$5,538.00		
Safety Vision 3 camera system		\$2,200.00	Furnish and install exterior duplex outlets		\$800.00		
Furnish and install docking station		\$1,275.00	<b>Subtotal From Additional Sheet(s):</b>		\$10,575.00		
Blackout cladding		\$1,650.00	<b>Subtotal C:</b>		\$24,638.00		
<b>Check: Total cost of Unpublished Options (C) cannot exceed 25% of the total of the Base Unit Price plus Published Options (A+B).</b>					<b>For this transaction the percentage is:</b>		9%
<b>D. Total Cost Before Any Applicable Trade-In / Other Allowances / Discounts (A+B+C)</b>							
<b>Quantity Ordered:</b>	1	<b>X Subtotal of A + B + C:</b>		\$312,338.00	=	<b>Subtotal D:</b>	\$312,338.00
<b>E. H-GAC Order Processing Charge (Amount Per Current Policy)</b>						<b>Subtotal E:</b>	\$1,000.00
<b>F. Trade-Ins / Special Discounts / Other Allowances / Freight / Installation / Miscellaneous Charges</b>							
<b>Description</b>		<b>Cost</b>	<b>Description</b>		<b>Cost</b>		
Trade In		-\$40,000.00	<b>Subtotal From Additional Sheet(s):</b>		\$0.00		
			<b>Subtotal F:</b>		-\$40,000.00		
<b>Delivery Date:</b>				<b>G. Total Purchase Price (D+E+F):</b>		\$273,338.00	

CONTINUATION SHEET (page 2)		Contract No.:	AM10-20	Date Prepared:	03/29/22
<b>B. Published Options - List below (continuation from page 1)</b>					
<b>(Note: Published Options are options which were submitted and priced in Contractor's bid.)</b>					
Description	Cost	Description	Cost		
1116 Module // Captain's Chair // Valor Captain's Chair with	\$2,000.00	1061 Chassis // Glove Box // 3 High Glove Box Holde	\$250.00		
1052 Chassis // Exhaust System	\$1,000.00	1042 Chassis // Console // 2 Large Aluminum Map Hd	\$400.00		
1088 Chassis // Tint // Chassis Window Tint	\$250.00	1046 Chassis // Console // Gamber Johnson Cup Hold	\$200.00		
1208 Module // Tint // Limo Tint on Entry Doors	\$350.00	1196 Module // Restraint // 6pt Harness (each) (includ	\$500.00		
1121 Module // Compartments // Flat bars on Rear Storage	\$250.00	1196 Module // Restraint // 6pt Harness (each) (includ	\$500.00		
1199 Module // SCBA // (2) SC-50-H-6-SF SCBA brackets	\$1,000.00	1196 Module // Restraint // 6pt Harness (each) (includ	\$500.00		
1118 Module // Coat Hooks // 4 Coat Hooks	\$200.00	1164 Module // Headknocker // Rear Wall Headknock	\$500.00		
1118 Module // Coat Hooks // 4 Coat Hooks	\$200.00	1202 Module // Shorepower // Dual 20/30 Kussmaul	\$750.00		
1200 Module // Scene Lights // Passenger Scene on with Doo	\$350.00	1043 Chassis // Console // Armrest	\$250.00		
1092 Chassis // Vinyl Seats // After-market Vinyl Seats in Tru	\$1,000.00	1209 Module // Trash Can // Large Black Trash Can	\$200.00		
1082 Chassis // Security // Anti-theft System	\$750.00				
1068 Chassis // Map Lights // Map Light on Both Sides	\$500.00				
		<b>Subtotal B (page 2):</b>			\$11,900.00
<b>C. Unpublished Options - List below (continuation from page 1)</b>					
<b>(Note: Unpublished options are items which were not submitted and priced in Contractor's bid.)</b>					
Description	Cost	Description	Cost		
Custom compartment over ps rear compartment	\$2,500.00				
Custom wider front io compartment	\$2,500.00				
Lower BTT's: 2 M6 lights on each side	\$825.00				
Furnish and install Mermaid MK-Micro H cooler	\$4,000.00				
Furnish and install 2/3 wide cpr seat	\$750.00				
		<b>Subtotal C (page 2):</b>			\$10,575.00
<b>F. Trade-Ins / Special Discounts / Other Allowances / Freight / Installation / Miscellaneous Charges (continuation from page 1)</b>					
Description	Cost	Description	Cost		
		<b>Subtotal F (page 2):</b>			\$0.00

# Flower Mound Fire Department - Type I - 14' Module Attachment 2

## with Side Entry Door Forward

### Front Wall

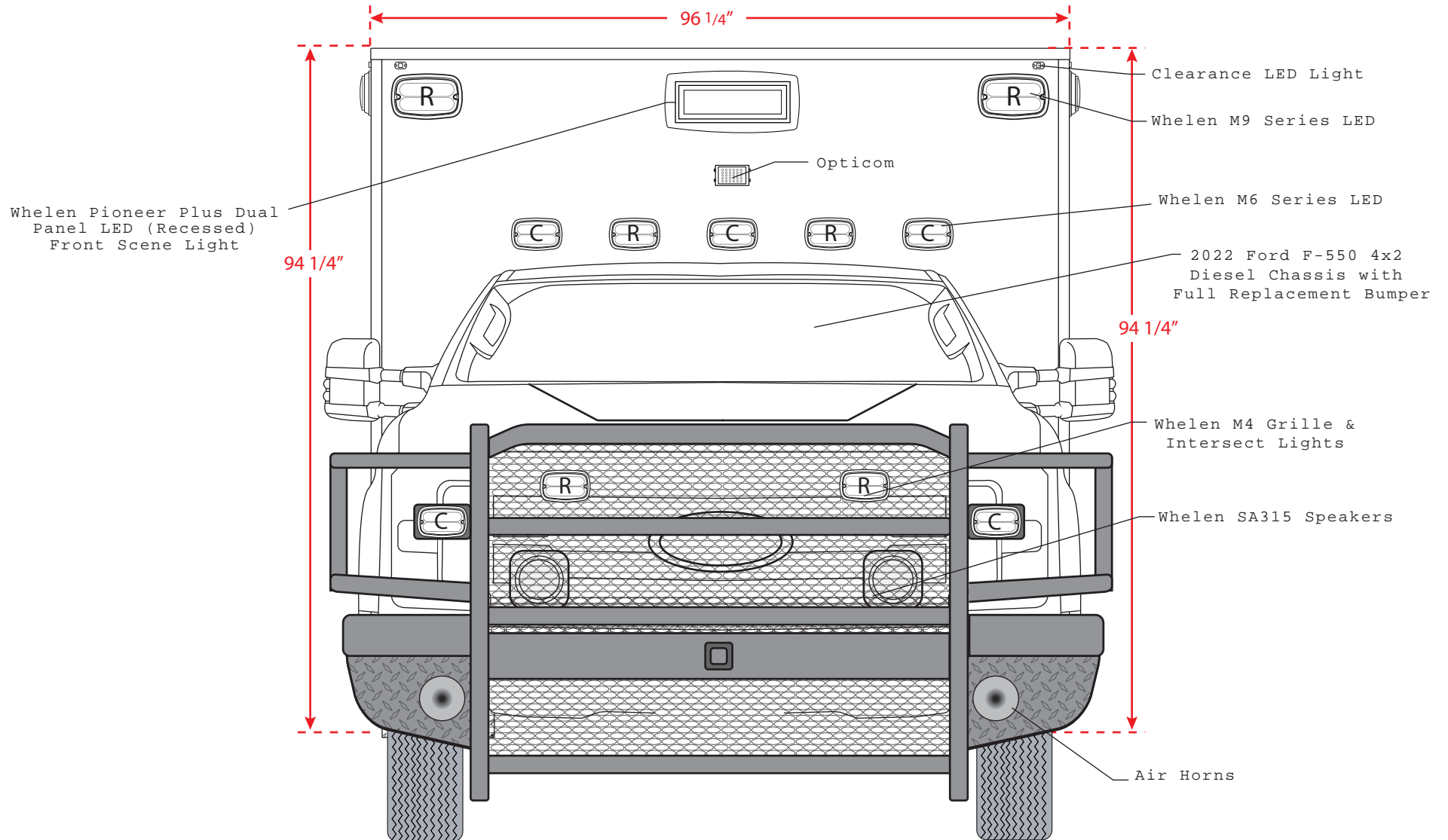

Note: Dimensions are tube to tube and approximate.

toll free: (888) 372-9371    Address: 7219 Rampart  
 main: (713) 772-5511       Houston, TX 77081  
 fax: (713) 995-0541  
 www.frazerbilt.com

Print No. 9918 Version 1 - Page 1 of 10

This drawing and all information thereon is the property of Frazer, Ltd. It is confidential and may not be reproduced or copied, whole or in part or be disclosed to others, without the specific written approval of Frazer, Ltd. It may be used solely for the purpose specified in writing and is subject to return upon demand.

DRAFT By: WB  
 QC By: AS



# Flower Mound Fire Department - Type I - 14' Module with Side Entry Door Forward Driver's Side Wall

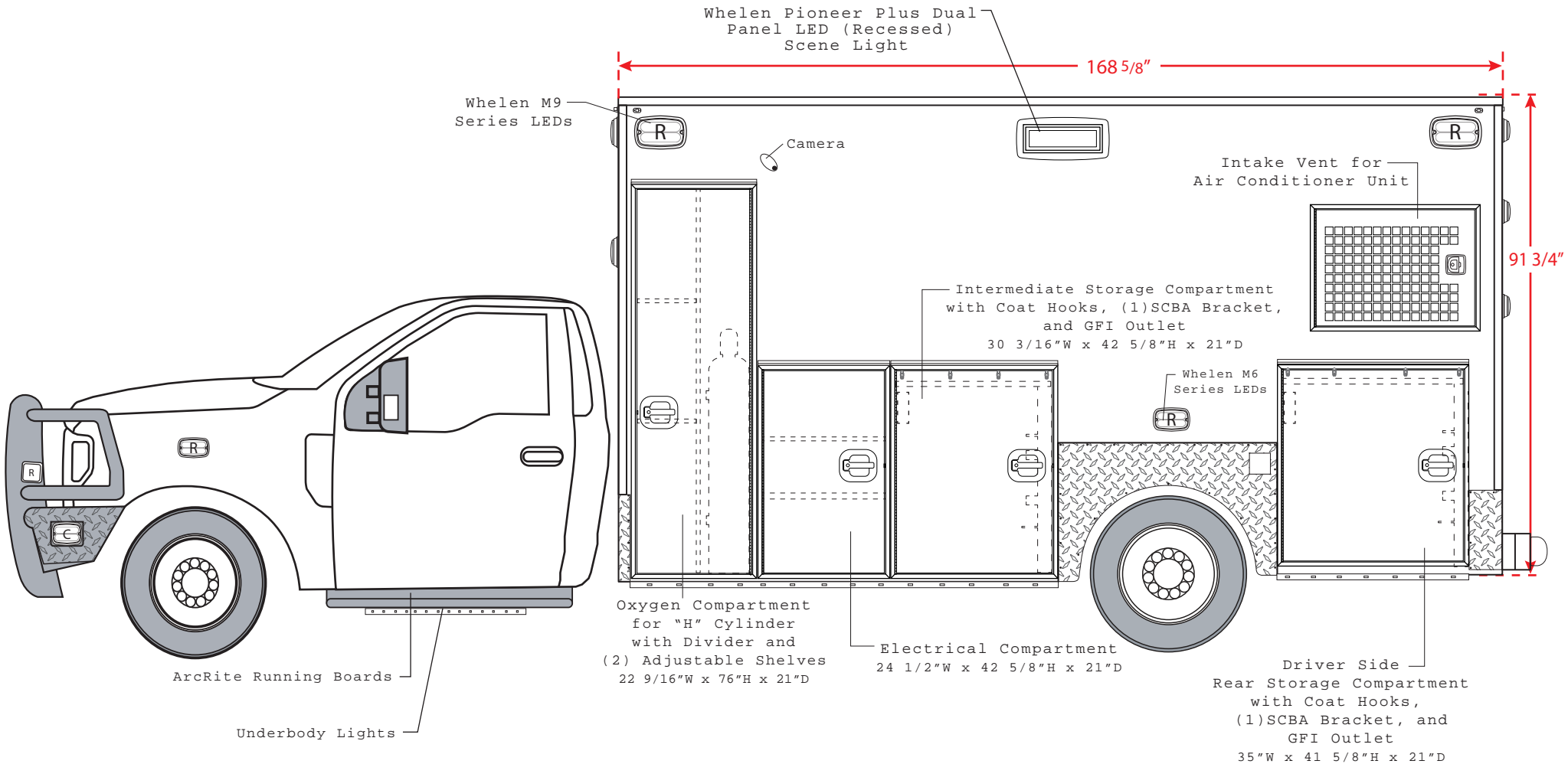

Note: Dimensions are tube to tube and approximate.

toll free: (888) 372-9371    Address: 7219 Rampart  
 main: (713) 772-5511       Houston, TX 77081  
 fax: (713) 995-0541  
 www.frazerbilt.com

Print No. 9918 Version 1 - Page 2 of 10

This drawing and all information thereon is the property of Frazer, Ltd. It is confidential and may not be reproduced or copied, whole or in part or be disclosed to others, without the specific written approval of Frazer, Ltd. It may be used solely for the purpose specified in writing and is subject to return upon demand.

DRAFT By: WB  
 QC By: AS

# Flower Mound Fire Department - Type I - 14' Module with Side Entry Door Forward Passenger's Side Wall

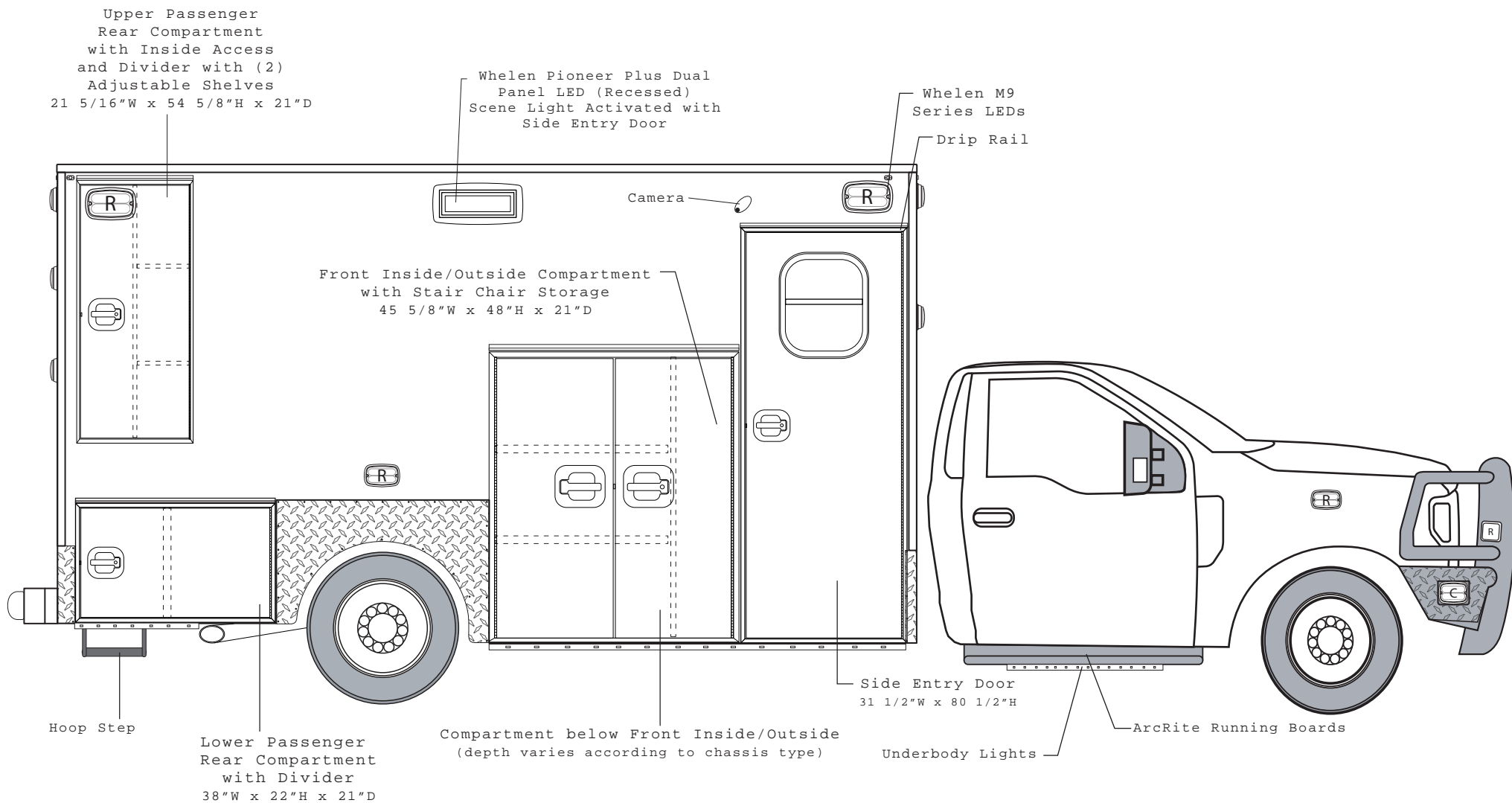

Note: Dimensions are tube to tube and approximate.

toll free: (888) 372-9371    Address: 7219 Rampart  
 main: (713) 772-5511       Houston, TX 77081  
 fax: (713) 995-0541  
 www.frazerbilt.com

Print No. 9918 Version 1 - Page 3 of 10

This drawing and all information thereon is the property of Frazer, Ltd. It is confidential and may not be reproduced or copied, whole or in part or be disclosed to others, without the specific written approval of Frazer, Ltd. It may be used solely for the purpose specified in writing and is subject to return upon demand.

DRAFT By: WB
QC By: AS

# Flower Mound Fire Department - Type I - 14' Module with Side Entry Door Forward

## Rear Wall

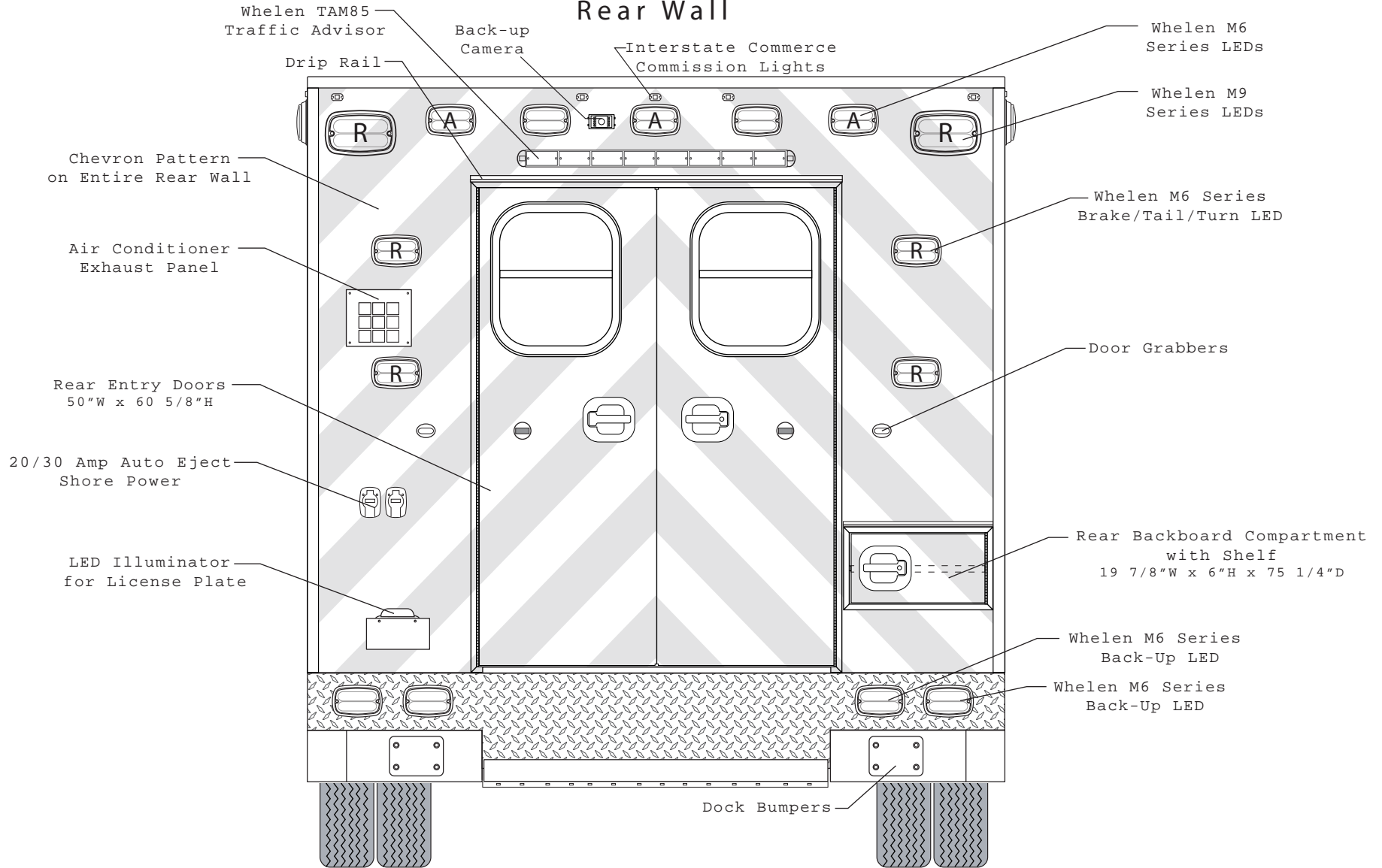

Note: Dimensions are tube to tube and approximate.

toll free: (888) 372-9371    Address: 7219 Rampart  
 main: (713) 772-5511    Houston, TX 77081  
 fax: (713) 995-0541  
 www.frazerbilt.com

Print No. 9918 Version 1 - Page 4 of 10

This drawing and all information thereon is the property of Frazer, Ltd. It is confidential and may not be reproduced or copied, whole or in part or be disclosed to others, without the specific written approval of Frazer, Ltd. It may be used solely for the purpose specified in writing and is subject to return upon demand.

DRAFT By: WB  
 QC By: AS

# Flower Mound Fire Department - Type I - 14' Module with Side Entry Door Forward Interior Front Wall

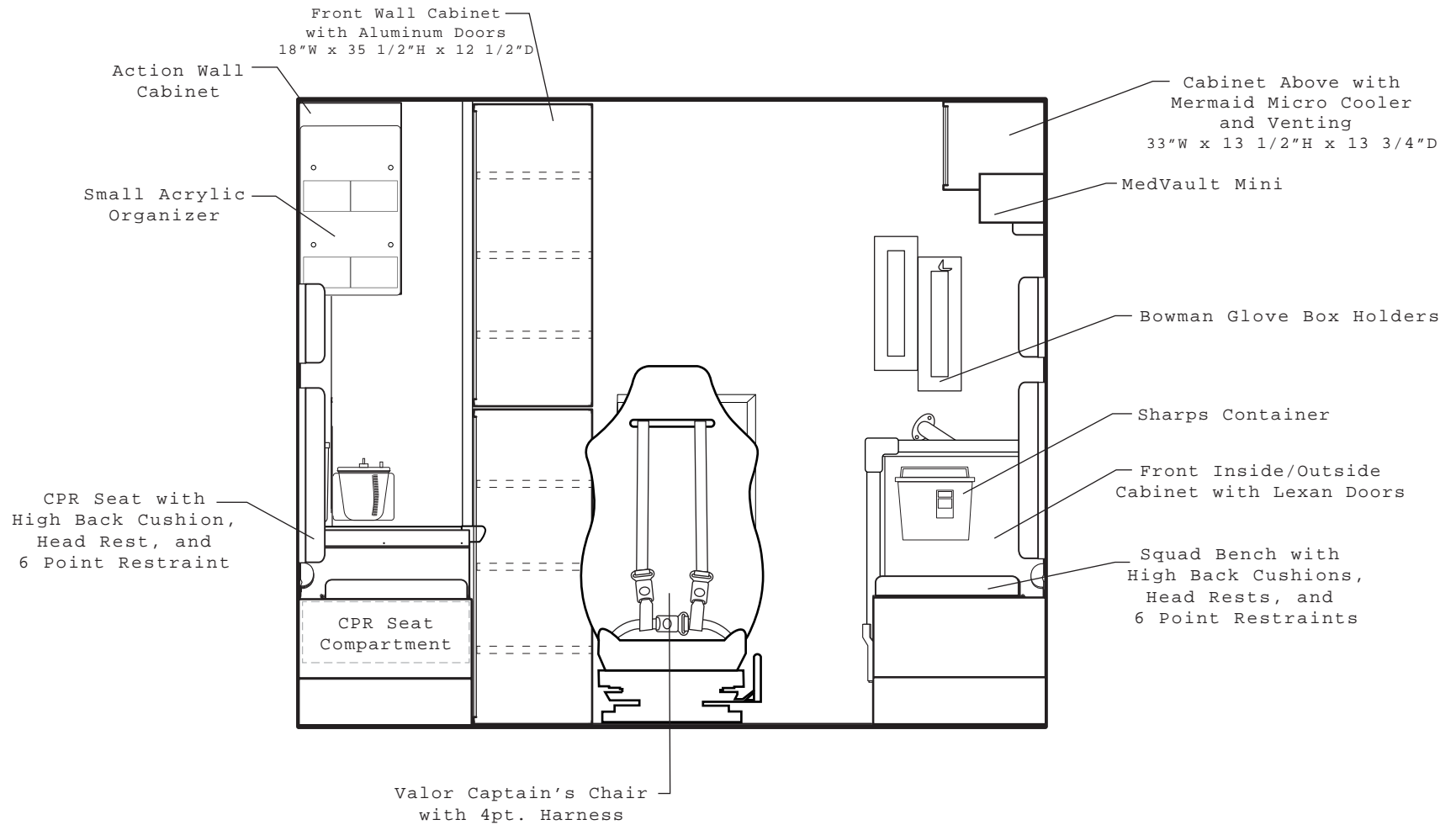

Note: Dimensions are approximate.

toll free: (888) 372-9371    Address: 7219 Rampart  
 main: (713) 772-5511       Houston, TX 77081  
 fax: (713) 995-0541  
 www.frazerbilt.com

Print No. 9918 Version 1 - Page 5 of 10

This drawing and all information thereon is the property of Frazer, Ltd. It is confidential and may not be reproduced or copied, whole or in part or be disclosed to others, without the specific written approval of Frazer, Ltd. It may be used solely for the purpose specified in writing and is subject to return upon demand.

DRAFT By: WB  
 QC By: AS

# Flower Mound Fire Department - Type I - 14' Module with Side Entry Door Forward Interior Driver's Side Wall

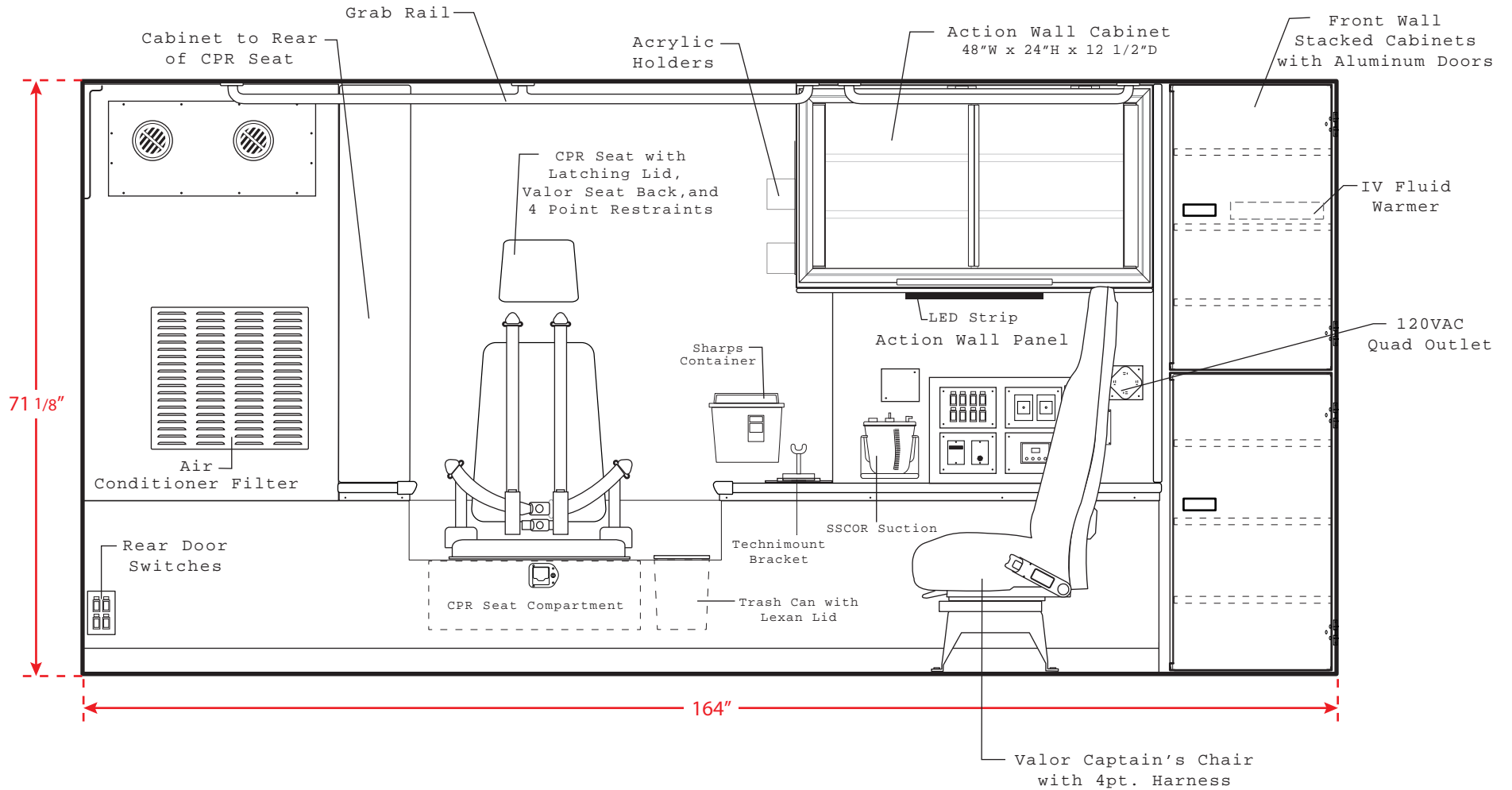

Note: Dimensions are approximate and cabinets have restocking feature.

toll free: (888) 372-9371    Address: 7219 Rampart  
 main: (713) 772-5511    Houston, TX 77081  
 fax: (713) 995-0541  
 www.frazerbilt.com

Print No. 9918 Version 1 - Page 6 of 10

This drawing and all information thereon is the property of Frazer, Ltd. It is confidential and may not be reproduced or copied, whole or in part or be disclosed to others, without the specific written approval of Frazer, Ltd. It may be used solely for the purpose specified in writing and is subject to return upon demand.

DRAFT By: WB  
 QC By: AS

# Flower Mound Fire Department - Type I - 14' Module with Side Entry Door Forward Interior Passenger's Side Wall

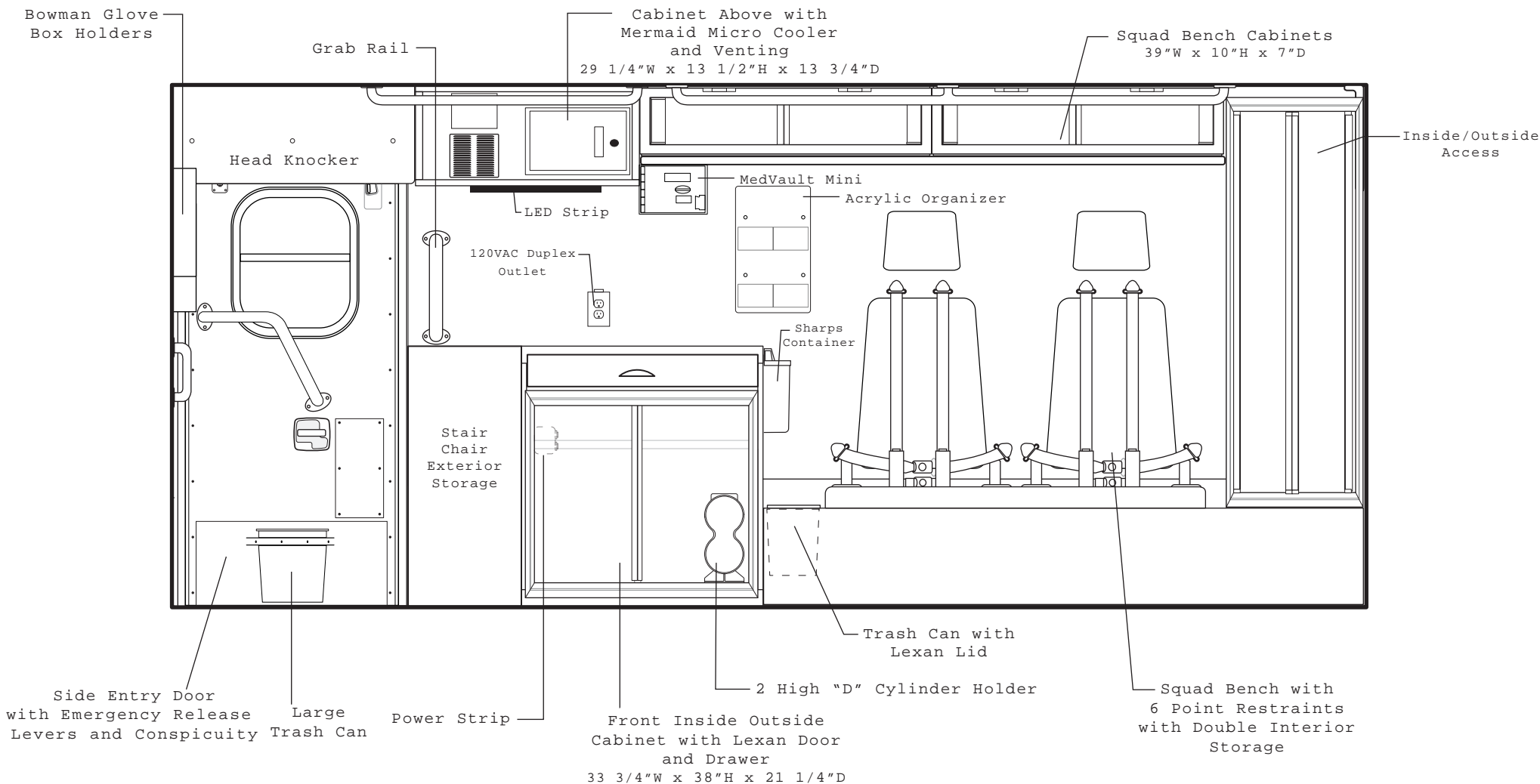

Note: Dimensions are approximate and cabinets have restocking feature.

toll free: (888) 372-9371    Address: 7219 Rampart  
 main: (713) 772-5511    Houston, TX 77081  
 fax: (713) 995-0541  
 www.frazerbilt.com

Print No. 9918 Version 1 - Page 7 of 10

This drawing and all information thereon is the property of Frazer, Ltd. It is confidential and may not be reproduced or copied, whole or in part or be disclosed to others, without the specific written approval of Frazer, Ltd. It may be used solely for the purpose specified in writing and is subject to return upon demand.

DRAFT By: WB  
 QC By: AS

# Flower Mound Fire Department - Type I - 14' Module with Side Entry Door Forward Interior Rear Wall

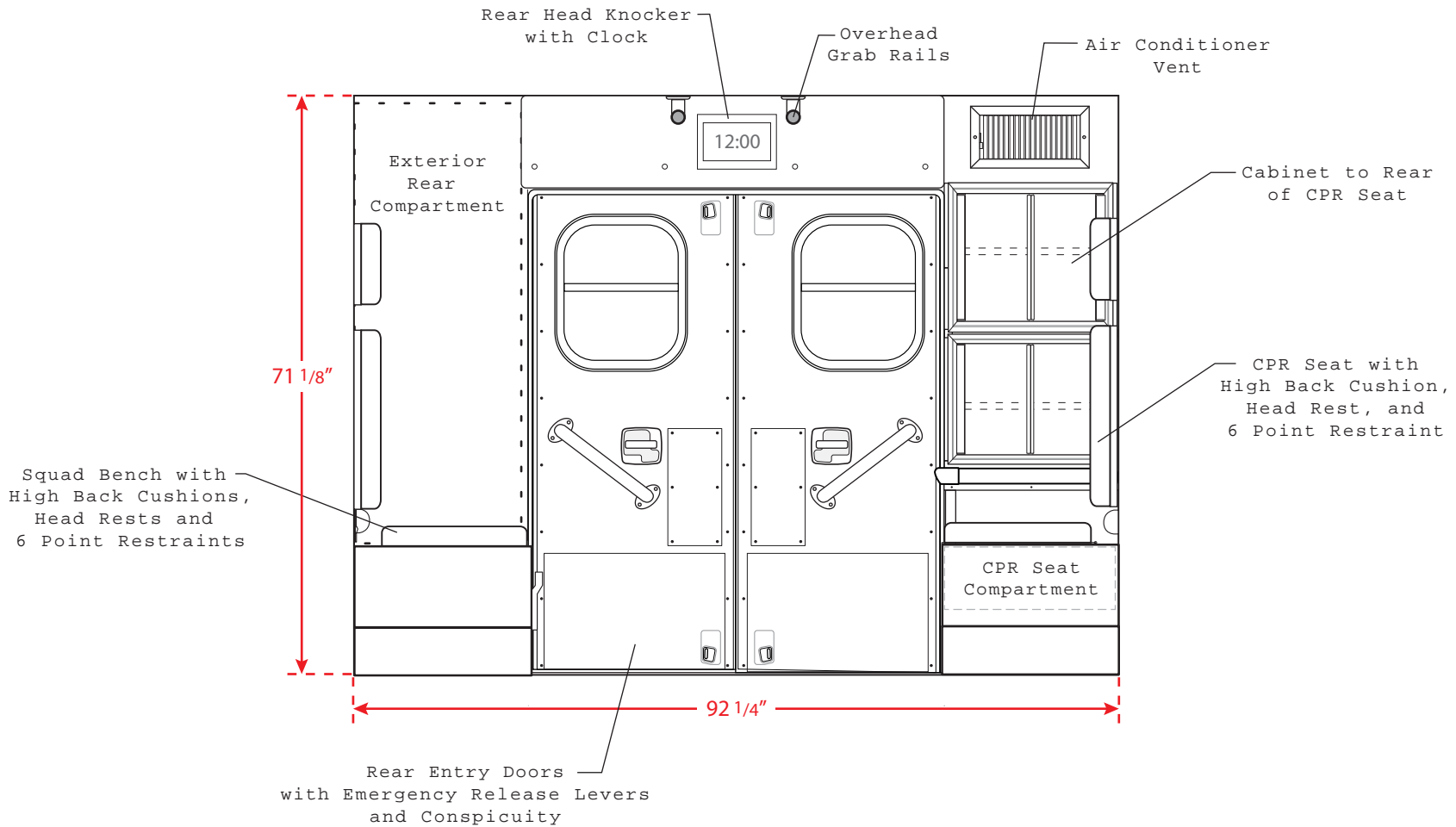

Note: Dimensions are approximate.

Print No. 9918 Version 1 - Page 8 of 10

toll free: (888) 372-9371    Address: 7219 Rampart  
 main: (713) 772-5511       Houston, TX 77081  
 fax: (713) 995-0541  
 www.frazerbilt.com

This drawing and all information thereon is the property of Frazer, Ltd. It is confidential and may not be reproduced or copied, whole or in part or be disclosed to others, without the specific written approval of Frazer, Ltd. It may be used solely for the purpose specified in writing and is subject to return upon demand.

DRAFT By: WB  
 QC By: AS

# Flower Mound Fire Department - Type I - 14' Module with Side Entry Door Forward Interior Ceiling

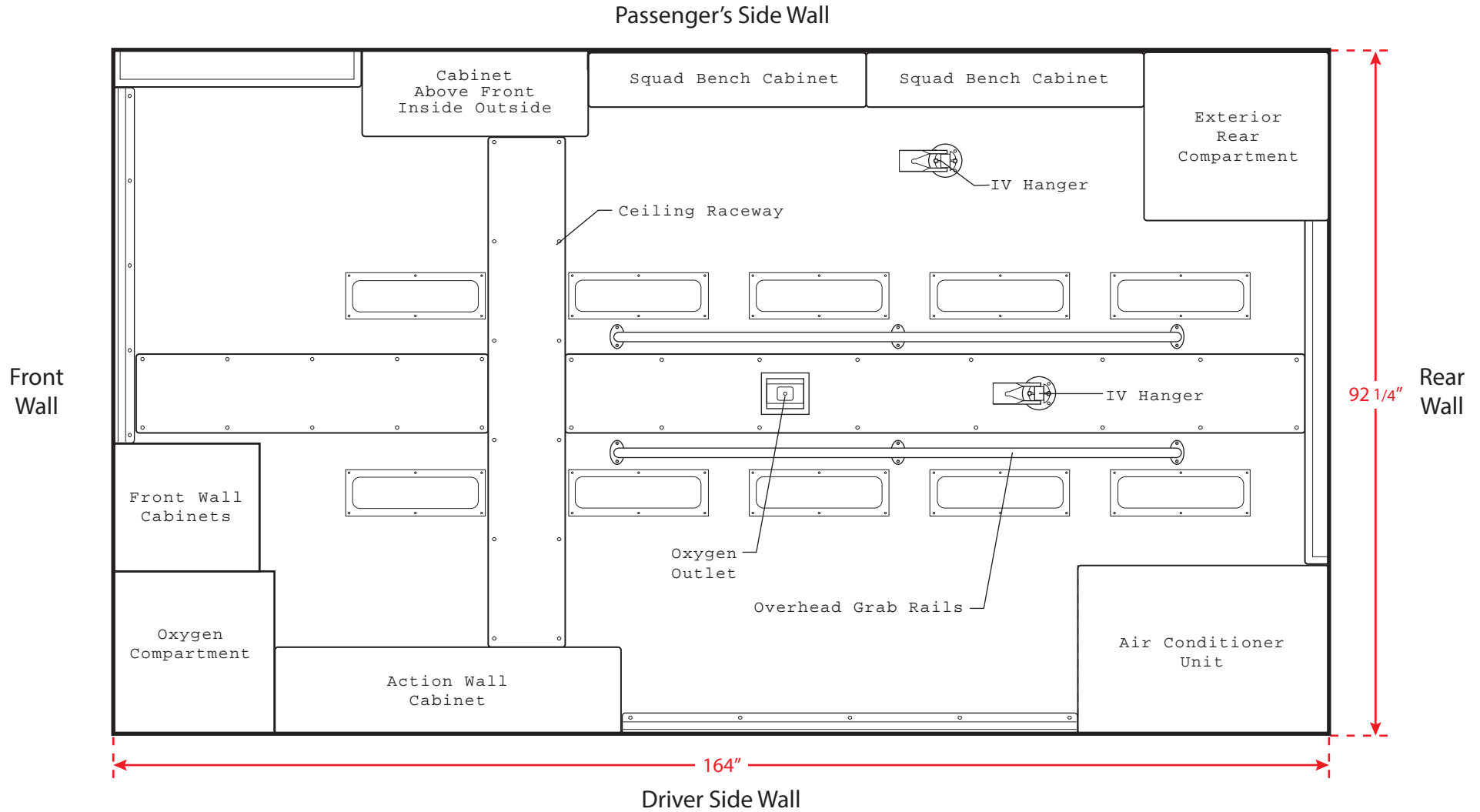

Note: Dimensions are approximate.

toll free: (888) 372-9371    Address: 7219 Rampart  
 main: (713) 772-5511       Houston, TX 77081  
 fax: (713) 995-0541  
 www.frazerbilt.com

Print No. 9918 Version 1 - Page 9 of 10

This drawing and all information thereon is the property of Frazer, Ltd. It is confidential and may not be reproduced or copied, whole or in part or be disclosed to others, without the specific written approval of Frazer, Ltd. It may be used solely for the purpose specified in writing and is subject to return upon demand.

DRAFT By: WB  
 QC By: AS



# Flower Mound Fire Department - Type I - 14' Module with Side Entry Door Forward

## Interior Floor

### Passenger's Side Wall

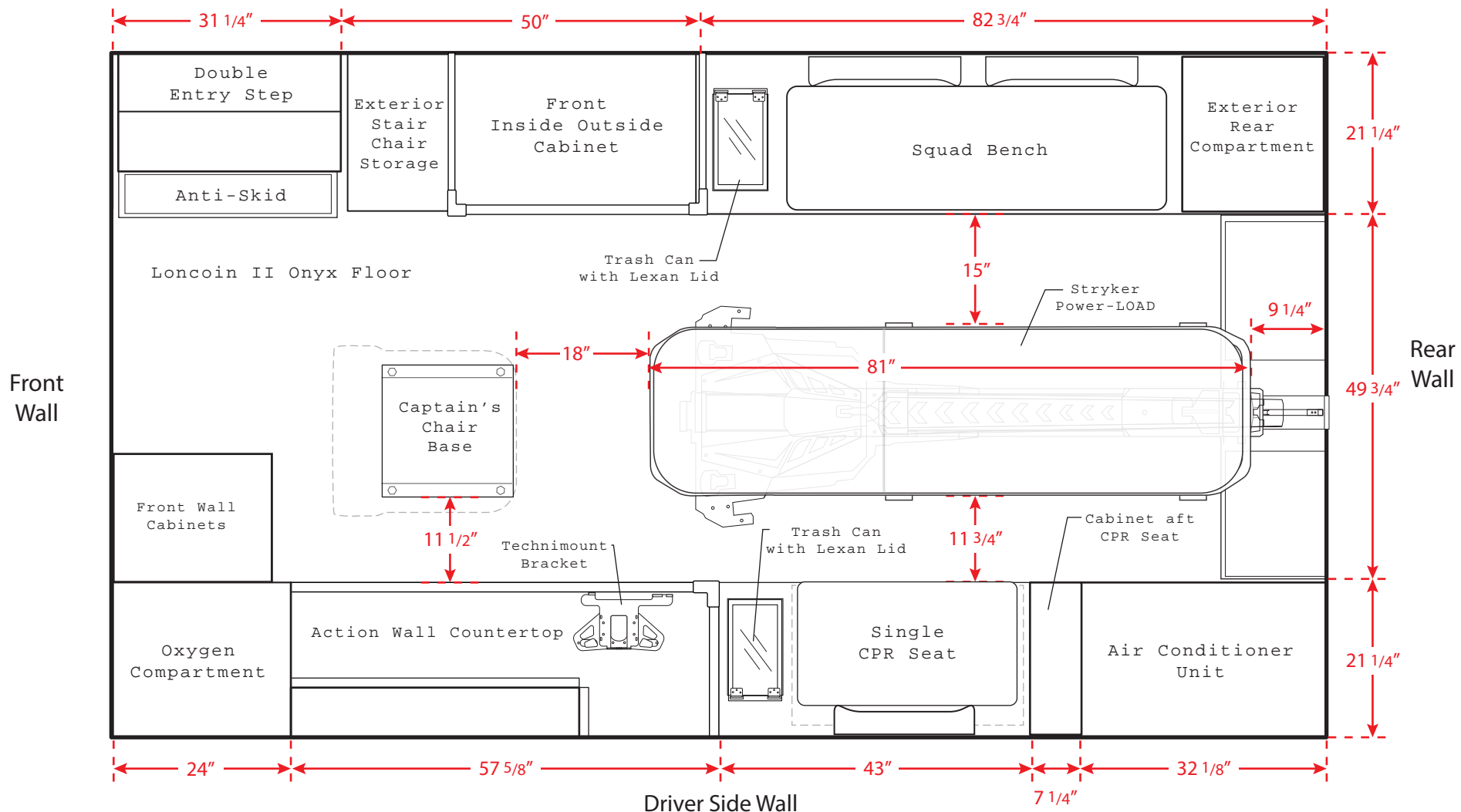

Note: Dimensions are approximate.

toll free: (888) 372-9371    Address: 7219 Rampart  
 main: (713) 772-5511       Houston, TX 77081  
 fax: (713) 995-0541  
 www.frazerbilt.com

Print No. 9918 Version 1 - Page 10 of 10

This drawing and all information thereon is the property of Frazer, Ltd. It is confidential and may not be reproduced or copied, whole or in part or be disclosed to others, without the specific written approval of Frazer, Ltd. It may be used solely for the purpose specified in writing and is subject to return upon demand.

DRAFT By: WB  
 QC By: AS



## Bid Award Recommendation

Date: 04/26/2022 – FY2023 Fire Department VEF Purchase

Description: **Frazer Medic on a 2023 Ford F450 Diesel 4x2 DRW Chassis**

Qty.: 1

*Replaces:* 61000-02, a 2015 Ford F450 Medic

Bidder: Sterling McCall Ford, Pablo Cantu, 281-588-5007,  
[pcantu@sterlingmccallford.com](mailto:pcantu@sterlingmccallford.com)

Item: 1 – 2023 Frazer Medic on a Ford F450 Diesel 4x2 DRW Chassis with Equipment and Options as Per Specifications Identified on HGACBuy Cooperative Contract# AM10-20 and Frazer TOFM Quote Q2869-0001.

Total Cost of Vehicles, Equipment & Installation:  
 (includes trade-in of TOFM Medic 61000-02) \$273,338.00

It is Fleet Services recommendation to award the bid to **Sterling McCall Ford** in the amount of **\$273,338.00** utilizing the **HGACBuy Cooperative Contract # AM10-20**.

04/26/2022

---

Fleet Services Manager

---

Date



## TOWN COUNCIL AGENDA ITEM NO. 3

### CONSENT ITEM

**DATE:** May 17, 2022

**FROM:** Theresa Scott, Town Secretary

**ITEM:** Consider approval of an ordinance canvassing returns and declaring results of a general election held May 7, 2022, for the purpose of electing Council Member Places 1 and 3 and providing an effective date.

**BACKGROUND INFORMATION:** A General Election was held on May 7, 2022, with voters casting ballots on Election Day and during early voting. The Town Charter (Sec. 5.07) and Texas Election Code (Sec. 67.003) requires canvassing the results after the election.

See attachment two and three for the unofficial results from Denton/Tarrant County. The results are considered official after the election canvass.

Town Charter 5.06. – Election by Majority.

At any regular or special election, the candidates in each place or office who shall have received the majority of votes cast in such election shall be declared elected.

**BOARD REVIEW/CITIZEN FEEDBACK:** N/A

**ALTERNATIVES/OPTIONS:** N/A

**FISCAL IMPACT:** N/A

**LEGAL REVIEW:** Bryn Meredith of Taylor, Olson, Adkins, Sralla, & Elam L.L.P., reviewed the canvass ordinance in 2021 as to form and legality. The same document is being executed tonight with changes to include dates, names, titles, results, and signature block updates.

**ATTACHMENTS:**

1. Draft ordinance
2. Unofficial Results – Denton County
3. Unofficial Results – Tarrant County

Attachments not available at the time of packet posting – these will be made available upon receipt from the Counties.

**DRAFT MOTION:** Move to approve as presented in the agenda caption.

# Town Council Future Agenda Items



<b>SCHEDULED</b>	<b>5/25/2022</b>	Presentation	Panel discussion regarding strategies to attract and promote economic development in the Town of Flower Mound, and more specifically Class A office space in the Lakeside Business District.
	<b>6/6/2022</b>	Consent	Consider approval of the purchase and installation of the 2021-22 Playground Replacements project, for Peacock Park Playground, from Childs Play, Inc., through the Texas Local Government Purchasing Cooperative, in the amount of \$243,189.00.
		Consent	Consider approval of a Professional Services Agreement with Tom Davis to provide Housing Rehabilitation Specialist services, and authorization for the Mayor to execute same on behalf of the Town.
		Consent	Consider approval of a Professional Services Agreement for the 2021 Water and Wastewater Model update project, with Kimley-Horn, for \$25,400; and authorization for the Mayor to execute same on behalf of the Town.
		Consent	Consider approval of an ordinance for a street name change for a section of roadway known as Boat Ramp on the eastern end of Lake Ridge Road to Lake Ridge Drive. (The Transportation Commission recommended to change the street name by a vote of 6 to 0 at its March 8, 2022, meeting)
		Consent	Consider approval of a Construction Agreement with GeoSurfaces, Inc. for the installation of artificial turf on the infield of field #11 at Bakersfield Park, through The Interlocal Purchasing System (TIPS), in the amount of \$169,070.00; and authorize for the Mayor to execute same on behalf of the Town
		Consent	Consider approval of an ordinance for a street name change for Bridgewater Avenue (200 - 300 block) to McConathy Way (200 - 300 block) (The Transportation Commission recommended to change the street name by a vote of X to X at its May 10, 2022, meeting)
		Consent	Consider approval of the minutes from a regular meeting of the Town Council held on May 17, 2022.
		Presentation	Transportation Commission Update
		Regular	Public Hearing to consider an ordinance granting Specific Use Permit No. 472 (SUP21-0005 – Bosco Boat Dealership) to permit inclusion of Retail, general (outdoors) use for a boat dealership within an existing car dealership facility. The property is generally located south of Justin Road and east of Stone Hill Farms Parkway. (P&Z recommended approval with conditions by a vote of 6 to 0 at its December 13, 2021, meeting.) (On February 7, 2022 Town Council postponed this item to the March 21, 2022 meeting by a vote of 5 to 0 at the Applicant's request). (On March 21, 2022 Town Council postponed this item to the June 6, 2022 meeting by a vote of 5 to 0 at the Applicant's request).

<b>SCHEDULED</b>	<b>6/6/2022</b>	Regular	Public Hearing to consider an ordinance for rezoning (ZPD21-0010 – Embree 2499) from Agricultural District (A) and Single Family-Estate (SF-E) to Planned Development District No. 186 (PD-186) with Retail-2 District (R-2) and Office District (O) uses, with certain modifications and exceptions to the Code of Ordinances. The property is generally located south of Sagebrush Drive and west of Long Prairie Road. (PZ recommended approval/denial by a vote of 0 to 0 at its May 23, 2022, meeting.)
	<b>6/20/2022</b>	Consent	High Road Water Line Phase II - Construction Award
		Consent	Consider approval of the minutes from a regular meeting of the Town Council held on June 6, 2022.
		Presentation	Proclamation for National Parks and Recreation Month
		Presentation	Veterans Liaison Board Update
		Presentation	All Together Flower Mound Commission Update
		Regular	Consider approval of an ordinance authorizing the issuance of the Town of Flower Mound, Texas, Certificates of Obligation, Series 2022, for the purpose of paying for waterworks and sewer system improvements, establishing parameters for the sale and issuance of such bonds, delegating certain matters to an authorized official of the Town and resolving all matters incident and related thereto.
	<b>7/18/2022</b>	Consent	Timber Creek Water & Sewer Replacements
		Consent	Rippy Road - Construction Award
		Consent	City Works Migration and Implementation Services
		Consent	Consider approval of the minutes from a regular meeting of the Town Council held on June 20, 2022.
		Regular	Public Hearing to consider a request to amend the Master Plan (MPA21-0010 - Parks and Trails Plan) by removing and replacing Section 5.0, "Parks and Trails Plan," and adopting the 2022 Trails and Bikeways Master Plan, and to consider adopting an ordinance providing for said amendments. (The Parks Board recommended approval of the proposed master plan update by a vote of ?-? at its June 2, 2022, meeting. The Transportation Commission recommended approval of the proposed master plan update by a vote of ?-? at its June 14, 2022, meeting. PZ recommended approval/denial by a vote of 0 to 0 at its June 13, 2022, meeting.)
	<b>8/8/2022</b>	Consent	Town Council acting as the Board of Directors for the Town of Flower Mound Crime Control and Prevention District to schedule a public hearing for August 22, 2022, on the Flower Mound Crime Control and Prevention District budget and to schedule a meeting for September 19, 2022, to take action on the proposed budget; with each meeting to be held at 6:00 PM, at Town Hall, located at 2121 Cross Timbers Road.

<b>SCHEDULED</b>	<b>8/8/2022</b>	Consent	Consider approval of an ordinance establishing the 2022 certified appraisal roll.
		Consent	Consider accepting the submission of the certified collection rate of 100 percent for the fiscal year beginning October 1, 2022, and ending September 30, 2023.
		Consent	Consider accepting the submission of the notice of a no-new-revenue tax rate of \$_____ per \$100 assessed valuation and a voter-approval tax rate of \$_____ per \$100 assessed valuation for the fiscal year beginning October 1, 2022, and ending September 30, 2023.
		Consent	Consider proposing a maximum tax rate of \$0._____ per \$100 valuation for the fiscal year beginning October 1, 2022, and ending September 30, 2023; and scheduling August 22, 2022, public hearing on the budget, scheduling September 19, 2022, public hearing on the tax rate, and scheduling the September 19, 2022, adoption of said budget and tax rate; with each meeting to be held at 6:00 PM, at Town Hall, located at 2121 Cross Timbers Road.
		Consent	Town Council acting as the Board of Directors for the Town of Flower Mound Fire Control, Prevention, and Emergency Medical Services District to schedule a public hearing for August 22, 2022, on the Flower Mound Fire Control, Prevention, and Emergency Medical Services District budget and to schedule a meeting for September 19, 2022, to take action on the proposed budget; with each meeting to be held at 6:00 PM, at Town Hall, located at 2121 Cross Timbers Road.
		Consent	Placeholder: Call Election for reauthorization of Crime, Fire, Streets tax.
	<b>8/18/2022</b>	Consent	Hold a discussion and provide direction regarding the FY 2022-2023 Proposed Budget, including Community Support funding.
	<b>8/22/2022</b>	Consent	Public Hearing by the Town Council acting as the Board of Directors for the Town of Flower Mound Crime Control and Prevention District to consider the Flower Mound Crime Control and Prevention District proposed budget for the fiscal year beginning on October 1, 2022, and ending on September 30, 2023.
		Consent	Public Hearing to consider the proposed budget for the fiscal year beginning on October 1, 2022, and ending on September 30, 2023.
		Consent	Public Hearing by the Town Council acting as the Board of Directors for the Town of Flower Mound Fire Control, Prevention, and Emergency Medical Services District to consider the Flower Mound Fire Control, Prevention, and Emergency Medical Services District proposed budget for the fiscal year beginning on October 1, 2022, and ending on September 30, 2023.
	<b>9/19/2022</b>	Consent	Consider approval of an ordinance adopting the budget for the fiscal year beginning on October 1, 2022, and ending on September 30, 2023, and making appropriations for each fund and department.
		Consent	Consider approval of an ordinance adopting the 2022 tax rolls and fixing and levying municipal ad valorem taxes for the fiscal year beginning on October 1, 2022, and ending on September 30, 2023, and for each fiscal year thereafter until otherwise provided, at the rate of \$0._____ per \$100 assessed valuation on all taxable property within the corporate limits of the Town of Flower Mound as of January 1, 2022.

<b>SCHEDULED</b>	<b>9/19/2022</b>	Consent	Town Council acting as the Board of Directors for the Town of Flower Mound Fire Control, Prevention, and Emergency Medical Services District to consider approval of a resolution adopting the Town of Flower Mound Fire Control, Prevention, and Emergency Medical Services District budget for the fiscal year beginning on October 1, 2022, and ending on September 30, 2023.
		Consent	Town Council acting as the Board of Directors for the Town of Flower Mound Crime Control and Prevention District to consider approval of a resolution adopting the Town of Flower Mound Crime Control and Prevention District budget for the fiscal year beginning on October 1, 2022, and ending on September 30, 2023.
		Consent	Public Hearing to consider a tax rate of \$0._____ per \$100 assessed valuation.